



PERGAMON

Journal of Steroid Biochemistry & Molecular Biology 86 (2003) 225–230

The Journal of
Steroid Biochemistry
&
Molecular Biology

www.elsevier.com/locate/jsbmb

Sources of estrogen and their importance[☆]

E.R. Simpson*

Monash Medical Center, Prince Henry's Institute of Medical Research, P.O. Box 5152, Clayton 3168, Vic., Australia

Abstract

In premenopausal women, the ovaries are the principle source of estradiol, which functions as a circulating hormone to act on distal target tissues. However, in postmenopausal women when the ovaries cease to produce estrogen, and in men, this is no longer the case, because estradiol is no longer solely an endocrine factor. Instead, it is produced in a number of extragonadal sites and acts locally at these sites as a paracrine or even intracrine factor. These sites include the mesenchymal cells of adipose tissue including that of the breast, osteoblasts and chondrocytes of bone, the vascular endothelium and aortic smooth muscle cells, and numerous sites in the brain. Thus, circulating levels of estrogens in postmenopausal women and in men are not the drivers of estrogen action, they are reactive rather than proactive. This is because in these cases circulating estrogen originates in the extragonadal sites where it acts locally, and if it escapes local metabolism then it enters the circulation. Therefore, circulating levels reflect rather than direct estrogen action in postmenopausal women and in men. Tissue-specific regulation of *CYP19* expression is achieved through the use of distinct promoters, each of which is regulated by different hormonal factors and second messenger signaling pathways. Thus, in the ovary, *CYP19* expression is regulated by FSH which acts through cyclic AMP via the proximal promoter II, whereas in placenta the distal promoter I.1 regulates *CYP19* expression in response to retinoids. In adipose tissue and bone by contrast, another distal promoter—promoter I.4—drives *CYP19* expression under the control of glucocorticoids, class 1 cytokines and TNF α . The importance of this unique aspect of the tissue-specific regulation of aromatase expression lies in the fact that the low circulating levels of estrogens which are observed in postmenopausal women have little bearing on the concentrations of estrogen in, for example, a breast tumor, which can reach levels at least one order of magnitude greater than those present in the circulation, due to local synthesis within the breast. Thus, the estrogen which is responsible for breast cancer development, for the maintenance of bone mineralization and for the maintenance of cognitive function is not circulating estrogen but rather that which is produced locally at these specific sites within the breast, bone and brain. In breast adipose of breast cancer patients, aromatase activity and *CYP19* expression are elevated. This occurs in response to tumor-derived factors such as prostaglandin E₂ produced by breast tumor fibroblasts and epithelium as well as infiltrating macrophages. This increased *CYP19* expression is associated with a switch in promoter usage from the normal adipose-specific promoter I.4 to the cyclic AMP responsive promoter, promoter II. Since these two promoters are regulated by different cohorts of transcription factors and coactivators, it follows that the differential regulation of *CYP19* expression via alternative promoters in disease-free and cancerous breast adipose tissue may permit the development of selective aromatase modulators (SAMs) that target the aberrant overexpression of aromatase in cancerous breast, whilst sparing estrogen synthesis in other sites such as normal adipose tissue, bone and brain.

© 2003 Published by Elsevier Ltd.

Keywords: Estrogen; *CYP19*; Aromatase

1. Introduction

In premenopausal women, the ovaries are the principle source of estradiol, which functions as a circulating hormone to act on distal target tissues. However, in postmenopausal women when the ovaries cease to produce estrogen, and in men, this is no longer the case. Instead, estrogens are produced in a number of extragonadal sites. Although this

has been in a general sense recognized, its significance is only now becoming appreciated, as will be explained further.

In postmenopausal women then, estradiol is no longer solely an endocrine factor. Instead, it is produced in a number of extragonadal sites and acts locally at these sites as a paracrine or even intracrine factor. These sites include the mesenchymal cells of adipose tissue including that of the breast, osteoblasts and chondrocytes of bone, the vascular endothelium and aortic smooth muscle cells, and numerous sites in the brain. Thus, circulating levels of estrogens in postmenopausal women and in men are not the drivers of estrogen action, they are reactive rather than proactive. This is because in these cases circulating estrogen originates in the extragonadal sites where it acts locally, and if it escapes

[☆] Presented at the VI International Aromatase Conference: AROMATASE 2002, Kyoto, Japan, 26–30 October 2002.

* Tel.: +61-3-9594-4397; fax: +61-3-9594-6376.

E-mail address: evan.simpson@med.monash.edu.au (E.R. Simpson).

local metabolism then it enters the circulation. Therefore, circulating levels reflect rather than direct estrogen action in postmenopausal women and in men [1–3].

2. Extragonadal estrogen biosynthesis

Extragonadal sites of estrogen biosynthesis possess several fundamental features that differ from those of the ovaries. First, the estrogen synthesized within these compartments acts predominantly at the local tissue level in a paracrine or intracrine fashion [4,5]. The total amount of estrogen synthesized by these extragonadal sites may be small but the local tissue concentrations achieved are probably high and exert biological influence locally. As a consequence, extragonadal estrogen biosynthesis plays an important but hitherto largely unrecognized physiological and pathophysiological role.

The power of local estrogen biosynthesis is illustrated by the cases of men in whom aromatase expression in adipose tissue is greatly increased, whereas aromatase expression present in the testes is unaffected. This results in florid gynecomastia and short stature due to premature epiphyseal fusion [6,7]. This condition is a consequence of chromosomal rearrangements that result in the insertion of a constitutive promoter upstream of the start of translation of the aromatase gene [7]. Another example relates to postmenopausal breast cancer [8]. It has been determined that the concentration of estradiol present in breast tumors of postmenopausal women is at least 20-fold greater than that present in the plasma. With aromatase inhibitor therapy, there is a precipitous drop in the intratumoral concentrations of estradiol and estrone together with a corresponding loss of intratumoral aromatase activity, indicating that this activity within the tumor and the surrounding breast adipose tissue is responsible for these high tissue concentrations [9].

In bone, aromatase is expressed primarily in osteoblasts and chondrocytes [10], and aromatase activity in cultured osteoblasts is comparable to that present in adipose stromal cells [11]. Thus, it appears that in bone also, local aromatase expression is the major source of estrogen responsible for the maintenance of mineralization, although this is extremely difficult to prove due to sampling problems. For both breast tumors and bone, therefore, it is likely that circulating estrogen levels have little impact on the relatively high endogenous tissue estrogen levels. Instead, the circulating levels merely reflect the sum of local formation in its various sites. This is a fundamental concept for the interpretation of relationships between circulating estrogen levels in postmenopausal women and estrogen insufficiency in specific tissues.

Another fundamental feature of extragonadal estrogen biosynthesis is that it is dependent on an external source of C₁₉ androgenic precursors, since these extragonadal sites are incapable of converting cholesterol to the C₁₉ steroids [5,12]. Thus, circulating levels of C₁₉ precursors become

extremely important in terms of providing adequate substrate for estrogen biosynthesis in these sites.

3. Sources of C₁₉ precursor for extragonadal estrogen formation

Testosterone circulates at concentrations which are an order of magnitude greater than those of estradiol in the blood of postmenopausal women (Table 1). An obvious implication of this realization is that androgens have an important role to play in female physiology. It is now recognized that much of the physiology of androgens is explicable in terms of the concept that testosterone functions as a circulating pro-hormone, which is converted in target tissues, on the one hand to 5 α -dihydrotestosterone (DHT) and on the other hand to estradiol. The former is the principal ligand for androgen receptors, and the latter is the principal ligand for both estrogen receptor α and β isoforms. Therefore, in any consideration of the roles of testosterone in either women or men, it is necessary to discuss both of these pathways of testosterone metabolism.

The situation is complicated by the fact that, in postmenopausal women, only about 25% of circulating testosterone is derived by direct secretion from the ovaries. The rest is formed largely from circulating precursors derived either from the adrenal cortex or from the ovaries. These are principally androstenedione, dehydroepiandrosterone (DHEA), and dehydroepiandrosterone sulfate (DHEAS). Whereas DHEAS is secreted entirely from the adrenals, androstenedione and DHEA are formed in both adrenals and ovaries. DHEA and DHEAS are present in the circulation in concentrations which are orders of magnitude greater than those of the active sex steroids (Table 1). Consequently, they form a large reservoir of precursor, which is available for conversion to testosterone and thus to estrogens in numerous peripheral tissue sites; it is also relatively insensitive, in the short term, to changes in secretion rates.

The fact that circulating testosterone levels in the postmenopausal woman are an order of magnitude greater than circulating estradiol levels (Table 1) suggests that circulating androgens might be more important for maintaining local estrogen levels in extragonadal sites than are circulating estrogens. Moreover, in men, circulating testosterone levels are

Table 1
Mean plasma steroid levels in men and in postmenopausal women

	Women (nmol/l)	Men (nmol/l)
T	0.6	12
Δ^4	2.5	4
E ₁	0.10	0.13
E ₂	0.04	0.10
DHEA	15	10
DHEAS	2500	2000

T: testosterone; E₁: estrone; E₂: estradiol; DHEA: dehydroepiandrosterone; DHEAS: dehydroepiandrosterone sulfate.

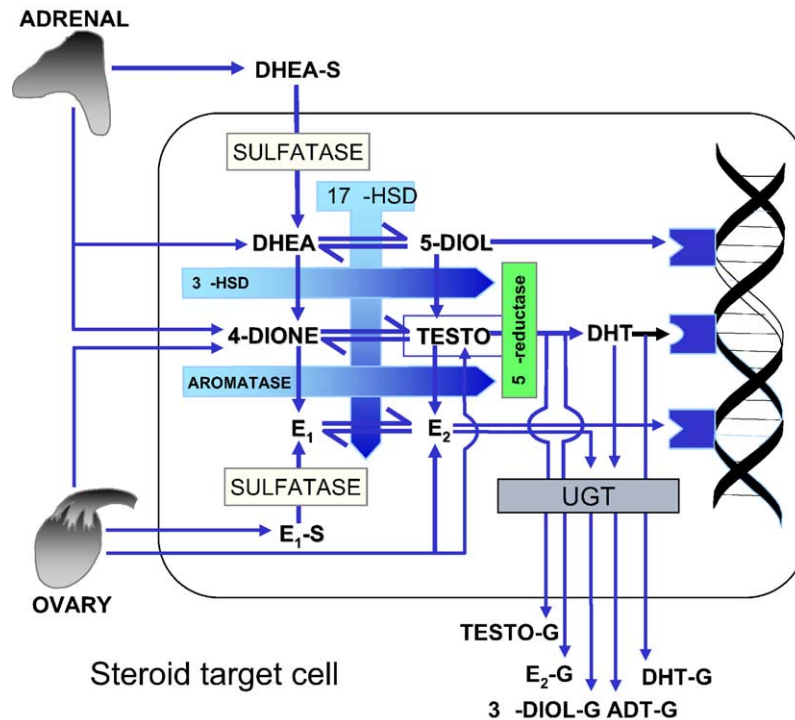

Fig. 1. 'Intracrine' interconversions between C₁₉ and C₁₈ steroids in steroid target cells. Quantitative aspects of the net flux will differ from cell type to cell type, but in general, the metabolism may not be reflected in changes in blood levels of active androgens or estrogens, but rather in their inactive metabolites, including reduced derivatives and conjugates. After Labrie et al. (2002), with permission.

an order of magnitude greater than those in postmenopausal women.

In this context, one may consider why osteoporosis is more common in women than in men and affects women at a younger age. Possibly, the uninterrupted sufficiency of circulating testosterone in men throughout life supports the local production of estradiol by aromatization of testosterone in estrogen-dependent tissues, and thus affords ongoing protection against the so-called estrogen deficiency diseases. This appears to be important in terms of protecting the bones of men against mineral loss and may also contribute to the maintenance of cognitive function and prevention of Alzheimer's disease [13].

As indicated previously, in postmenopausal women, the ovaries secrete about 25% of the circulating testosterone directly. The remainder is formed peripherally from androstenedione, DHEA and DHEAS (Fig. 1). The secretion of these steroids and their plasma concentrations, however, decrease markedly with advancing age [12]. Moreover, DHEA must first be converted to androstenedione prior to aromatization. Another major step is the reduction of the 17-keto group to the 17 β -hydroxyl catalyzed by one or more members of the 17 β -HSD family, which is essential for formation of the active estrogen, estradiol. The distribution of these enzymes in various extragonadal sites of aromatization has not yet been fully established, although reductive and/or oxidative members are expressed in many tissues. Thus, the metabolism of DHEAS is tissue-specific, and depends on

the profile of metabolizing enzymes in each tissue [4]. An extremely important point is that this metabolism is not reflected in changes in blood levels of active androgens or estrogens, but rather in their inactive metabolites, which include reduced derivatives, and glucuronide and sulfate conjugates. Thus, DHEA is converted to active hormones in local sites without leakage of significant amounts of these active hormones into the circulation. This emphasizes once more the point that neither the levels of circulating estrogens nor of their precursors are likely to be of significance in assessing either the concentration of estrogen or the availability of precursor in a particular extragonadal site [4]. It has been estimated that in men as much as 30–40% of total androgens are synthesized in peripheral tissues from inactive adrenal precursors, whereas in postmenopausal women more than 75% are synthesized in this fashion. Moreover, although the circulating testosterone levels are much lower in women than in men, total androgen production in women may be as much as 70% of that in men.

4. Non-sexually dimorphic roles of androgens and estrogens

Studies employing models of estrogen insufficiency have revealed new and unexpected roles for estradiol in both females and males [13]. These models include mutations in humans of the aromatase gene, of which 10 cases are

documented, 3 of whom are men [14,15], and 1 case of a man with a mutation in the estrogen receptor α (ER α) [16]. They also include mice with targeted disruptions of ER α and ER β ; the double ER α - and ER β -knockout mouse [17–20] as well as the aromatase-knockout (ArKO) mouse [21–23]. Recently described consequences of estrogen deprivation challenge the traditional beliefs of gender-specificity of sex steroid actions. For example, the lipid and carbohydrate phenotype of estrogen insufficiency is not sexually dimorphic and appears to apply to both males and females [23,24], as does the bone phenotype of undermineralization and failure of epiphyseal closure [25]. Even more dramatically, the roles of estradiol in male germ cell development and efferent duct fluid transport would indicate that, in this local context, estradiol might be more appropriately defined as an androgen [26–28].

Thus, there is a growing appreciation that both androgens and estrogens have general metabolic roles that are not directly involved in reproductive processes and apply, to a greater or lesser extent, to both sexes. This is perhaps more readily understood when placed in the context of the emerging knowledge of the evolution of steroidogenic genes on the one hand those encoding steroid hormone receptors on the other.

Largely from the work of Callard and co-workers, it is now recognized that the biosynthesis of estrogens occurs throughout the entire vertebrate phylum, including mammals, birds, reptiles, amphibians, teleosts, and elasmobranch fish as well as agnatha (hagfish and lampreys), and in protochordates such as amphioxus [29,30]. Consistent with this, phylogenetic analysis of steroid receptors in lower vertebrates indicates that the first steroid receptor was an estrogen receptor, followed by a progesterone receptor [31]. No equivalents of the ‘classical’ steroid receptors have been found in any species outside the vertebrates, although an ortholog of the estrogen-related receptor (ERR) is present in *Drosophila*, namely the ecdysone receptor.

Genome mapping and phylogenetic analysis indicate that the full complement of mammalian steroid receptors evolved from these ancient receptors by two large-scale genomic expansions—one before the advent of jawed vertebrates and one after [31]. Specific regulation of physiological processes by androgens and corticoids are relatively recent innovations that emerged after these duplications. Thus, we might speculate that the role of C₁₉ steroids was, in the first instance, merely to serve as a precursor for the estrogenic steroids, and that specific physiological roles for C₁₉ steroids only emerged later. On this basis, it is reasonable to expect that estrogens should play important physiological roles in males just as they do in females. It is also consistent with the observation that, at least in placental mammals, the female phenotype is the default phenotype, and that the difference between ‘maleness’ and ‘femaleness’ is not an absolute one, but instead is governed by a subtle balance of the ratios of estrogenic versus androgenic actions.

5. Significance of tissue-specific regulation of aromatase expression

Estrogen biosynthesis from C₁₉ steroids is catalyzed by the enzyme aromatase cytochrome P450. Aromatase is encoded by the *CYP19* gene which maps to chromosome 15q21.2 in humans. The structure and hormonal regulation of *CYP19* is complex, the gene spans 120 kb with a coding region of 30 kb comprising nine translated exons [7,32]. A number of untranslated exons I each associated with a unique promoter exist upstream of exon II. These are spliced into a common site in the 5′-untranslated region, ensuring that the coding region and hence protein is identical in every tissue site of expression. Tissue-specific regulation of *CYP19* expression is achieved through the use of these distinct promoters, each of which is regulated by different hormonal factors and second messenger signaling pathways. Thus, in the ovary, *CYP19* expression is regulated by FSH which acts through cyclic AMP via the proximal promoter II, whereas in placenta the distal promoter I.1 regulates *CYP19* expression in response to retinoids. In adipose tissue and bone by contrast, another distal promoter—promoter I.4—drives *CYP19* expression under the control of glucocorticoids, class 1 cytokines and TNF α (reviewed in [32]).

The importance of this unique aspect of the tissue-specific regulation of aromatase expression lies in the fact that the low circulating levels of estrogens which are observed in postmenopausal women have no bearing on the concentrations of estrogen reached in extragonadal sites of production due to local synthesis, as stated earlier. The significance of this paradigm shift cannot be underestimated, namely that the estrogen which is responsible for breast cancer development, for the maintenance of bone mineralization and for the maintenance of cognitive function is not circulating estrogen but rather that which is produced locally at these specific sites within the breast, bone and brain. These concepts are only now being accepted [2] and lead to the following considerations.

As stated earlier, in adipose tissue including that of breast, and in bone, a distal promoter namely promoter I.4 drives *CYP19* expression under the control of glucocorticoids, class 1 cytokines of TNF α . However, in breast adipose of breast cancer patients, aromatase activity and *CYP19* expression are elevated [33]. This occurs in response to tumor-derived factors such as prostaglandin E₂ [34] produced by breast tumor fibroblasts and epithelium as well as infiltrating macrophages. This increased *CYP19* expression we showed previously is associated with a switch in promoter usage from the normal adipose-specific promoter I.4 to the cyclic AMP responsive promoter, promoter II [33,35]. Since these two promoters are regulated by different cohorts of transcription factors and coactivators, it follows that the differential regulation of *CYP19* expression via alternative promoters in disease-free and cancerous breast adipose tissue may permit the development of selective aromatase

modulators (SAMs) that target the aberrant overexpression of aromatase in cancerous breast, whilst sparing estrogen synthesis in other sites such as normal adipose tissue, bone and brain. A more complete understanding of the mechanisms regulating *CYP19* transcription from promoter II in breast adipose tissue therefore, is an essential prerequisite for the development of such SAMs.

Why is the development of SAMs important from a therapeutic standpoint? This stems from the fact that the local source of estrogen in a breast tumor and surrounding tissue provides the drive for growth of estrogen receptor positive tumors and is the target of anti-estrogen adjuvant therapies in postmenopausal women [36]. Recently, several highly specific, high affinity inhibitors of the catalytic activity of aromatase have been developed, notably the Novartis compound letrozole and the AstraZeneca compound arimidex. In a number of trials including the recently highly publicized large-scale trial (the ATAC trial) [37–39], these compounds have been shown to be superior to tamoxifen as adjuvant therapy for breast cancer and are likely to replace tamoxifen in a number of modalities of treatment. Since these compounds inhibit aromatase globally, that is in all sites of synthesis, they have the potential to adversely affect bone mineralization, accumulation of fat in the liver, cognitive function and hot flushes [2,36]. While this may not be a major problem in treatment of elderly women with advanced disease, for young postmenopausal women with early onset disease or in the chemo-prevention setting, these problems could reach serious proportions.

Clearly if one could selectively inhibit aromatase expression within the breast, but spare the other sites of local expression, then one could offer a clear therapeutic advantage, particularly to these categories of patients. The fact that the proximal promoter II drives aromatase expression in breast tissue in the presence of a tumor, uniquely allows for this possibility, since the ovaries are no longer expression aromatase and we have shown conclusively that promoter II is never utilized in bone cells under any circumstances [40]. Hence factors that regulate aromatase expression in breast mesenchymal and tumor cells via promoter II are potential targets for such drug development.

Acknowledgements

This work was supported by a grant from the Victorian Breast Cancer Research Consortium Inc., and by USPHS Grant # R37AG08174. Sue Elger provided invaluable editorial assistance.

References

- [1] E.R. Simpson, C. Clyne, K. Robertson, L. O'Donnell, M. Jones, S. Davis, The role of local estrogen biosynthesis in males and females, *Trends Endocrinol. Metab.* 11 (2000) 184–188.
- [2] E.R. Simpson, S.R. Davis, Minireview: aromatase and the regulation of estrogen biosynthesis—some new perspectives, *Endocrinology* 142 (2001) 4589–4594.
- [3] E.R. Simpson, C. Clyne, G. Rubin, W.-C. Boon, K. Robertson, K. Britt, C. Speed, M. Jones, Aromatase—a brief overview, *Annu. Rev. Physiol.* 64 (2002) 93–127.
- [4] F. Labrie, A. Belanger, L. Cusan, B. Candas, Physiological changes in dehydroepiandrosterone are not reflected by serum levels of active androgens and estrogen but of their metabolites' intracrinology, *J. Clin. Endocrinol. Metab.* 82 (1997) 2403–2409.
- [5] F. Labrie, A. Belanger, V. Luu-The, C. Labrie, J. Simond, L. Cusan, J.L. Gomez, B. Candas, DHEA and the intracrine formation of androgens and estrogens in peripheral target tissues: its role during aging, *Steroids* (1998) 322–328.
- [6] J.D. Wilson, J. Aiman, P.C. MacDonald, The pathogenesis of gynecomastia, *Adv. Intern. Med.* 25 (1980) 1–32.
- [7] S. Sebastian, M. Shozu, W. Hsu, J. Sarkey, R. Schultz, K. Neely, et al., Estrogen excess caused by gain-of-function mutations of the *cyp19* (aromatase) gene involving the chromosome 15q 21.2–q21.3 region, in: *Proceedings of the 83rd Annual Meeting of the Endocrine Society*, vol. 127, Denver, CO, 2001 (Abstract).
- [8] J.R. Pasqualini, G. Chetrite, C. Blacker, M.C. Feinstein, I. Delalonde, M. Talbi, et al., Concentrations of estrone, estradiol, and estrone sulfate and evaluation of sulfatase and aromatase activities in pre- and postmenopausal breast cancer patients, *J. Clin. Endocrinol. Metab.* 81 (1996) 1460–1464.
- [9] P.C. DeJong, J. ven de Ven, H.W. Nortier, I. Maitimu-Sneede, T.H. Danker, J.H. Thijssen, et al., Inhibition of breast cancer tissue aromatase activity and estrogen concentrations by the third-generation aromatase inhibitor varozole, *Cancer Res.* 57 (1997) 2109–2111.
- [10] H. Sasano, M. Uzuki, T. Sawai, H. Nagura, G. Matsunaga, O. Kashimoto, et al., Aromatase in bone tissue, *J. Bone Miner. Res.* 12 (1997) 1416–1423.
- [11] M. Shozu, E.R. Simpson, Aromatase expression of human osteoblast-like cells, *Mol. Cell. Endocrinol.* 139 (1998) 117–129.
- [12] F. Labrie, A. Belanger, L. Cusan, J.L. Gomez, B. Candas, Marked decline in serum concentrations of adrenal C₁₉ sex steroid precursor, *J. Clin. Endocrinol. Metab.* 82 (1997) 2396–2402.
- [13] E.R. Simpson, G. Rubin, C. Clyne, K. Robertson, L. O'Donnell, M. Jones, S. Davis, The role of local estrogen biosynthesis in males and females, *Trends Endocrinol. Metab.* 11 (2000) 184–188.
- [14] A. Morishima, M.M. Grumbach, E.R. Simpson, C. Fisher, K. Qin, Aromatase deficiency in male and female siblings caused by a novel mutation and the physiological role of estrogens, *J. Clin. Endocrinol. Metab.* 80 (1995) 3689–3698.
- [15] C. Carani, K. Qin, M. Simoni, M. Faustini-Fustini, S. Serpente, J. Boyd, et al., Effect of testosterone and estradiol in a man with aromatase deficiency, *N. Engl. J. Med.* 337 (1997) 91–95.
- [16] E.P. Smith, J. Boyd, G.R. Frank, H. Takahashi, R.M. Cohen, B. Specker, et al., Estrogen resistance caused by a mutation in the estrogen-receptor gene in a man, *N. Engl. J. Med.* 331 (1994) 1056–1061.
- [17] D.B. Lubahn, J.S. Moyer, T.S. Golding, J.F. Couse, K.S. Korach, O. Smithies, Alteration of reproductive function but not prenatal sexual development after insertional disruption of the mouse estrogen receptor gene, *Proc. Natl. Acad. Sci. U.S.A.* 90 (1993) 11162–11166.
- [18] J.H. Kreege, J.B. Hodgin, J.F. Couse, E. Enmark, M. Warner, J.F. Mahler, et al., Generation and reproductive phenotypes of mice lacking estrogen receptor- β , *Proc. Natl. Acad. Sci. U.S.A.* 95 (1998) 15677–15682.
- [19] J.F. Couse, S.C. Hewitt, D.O. Bunch, M. Sar, V.R. Walker, B.J. Davis, et al., Postnatal sex reversal of the ovaries in mice lacking estrogen receptors α and β , *Science* 286 (1999) 2328–2331.
- [20] S. Dupont, A. Krust, A. Gansmuller, A. Dierich, P. Chambon, M. Mark, Effect of single and compound knockouts of estrogen receptor alpha (ER α) and beta (ER β) on mouse reproductive phenotypes, *Development* 127 (2000) 4277–4291.

- [21] C.R. Fisher, K.H. Graves, A.F. Parlow, E.R. Simpson, Characterization of mice deficient in aromatase (ArKO) because of targeted disruption of the *cyp19* gene, *Proc. Natl. Acad. Sci. U.S.A.* 95 (1998) 6965–6970.
- [22] S. Honda, N. Harada, Y. Takagi, S. Maeda, Disruption of sexual behaviour in male aromatase-deficient mice lacking exons 1 and 2 of the *cyp19* gene, *Biochem. Biophys. Res. Commun.* 252 (1998) 445–449.
- [23] Y. Nemoto, K. Toda, M. Ono, K. Fujikawa-Adachi, T. Saibara, S. Onishi, et al., Altered expression of fatty acid metabolising enzymes in aromatase-deficient mice, *J. Clin. Invest.* 105 (2000) 1819–1825.
- [24] M.E.E. Jones, A.W. Thorburn, K.L. Britt, K.N. Hewitt, N.G. Wreford, J. Proietto, et al., Aromatase-deficient (ArKO) mice have a phenotype of increased adiposity, *Proc. Natl. Acad. Sci. U.S.A.* 97 (2000) 12735–12740.
- [25] O.K. Oz, J.E. Zerwekh, C. Fisher, K. Graves, L. Nanu, R. Millsaps, et al., Bone has a sexually dimorphic response to aromatase deficiency, *J. Bone Miner. Res.* 15 (2000) 507–514.
- [26] K. Robertson, L. O'Donnell, M.E.E. Jones, S.J. Meachem, W.C. Boon, C.R. Fisher, et al., Impairment of spermatogenesis in mice lacking a functional aromatase (*cyp19*) gene, *Proc. Natl. Acad. Sci. U.S.A.* 96 (1999) 7986–7991.
- [27] E.M. Eddy, T.F. Washburn, D.O. Bunch, E.H. Goulding, B.C. Gladen, D.B. Lubahn, et al., Targeted disruption of the oestrogen receptor gene in male mice causes alteration of spermatogenesis and infertility, *Endocrinology* 137 (1996) 4796–4805.
- [28] M. Nakai, J. Bouma, R. Nie, Q. Zhou, K. Carnes, D.B. Lubahn, et al., Morphological analysis of endocytosis in efferent ductules of estrogen receptor-alpha knockout male mouse, *Anat. Rec.* 263 (2001) 10–18.
- [29] G.V. Callard, Z. Petro, K.J. Ryan, Phylogenetic distribution of aromatase and other androgen-converting enzymes of the central nervous system, *Endocrinology* 103 (1978) 2283–2290.
- [30] M. Kishida, G.V. Callard, Distinct cytochrome P450 aromatase isoforms in zebrafish (*D. rerio*) brain and ovary are differentially regulated during early development, *Endocrinology* 142 (2001) 740–750.
- [31] J.W. Thornton, Evolution of vertebrate steroid receptors from an ancestral estrogen receptor by ligand exploitation and serial genome expansions, *Proc. Natl. Acad. Sci. U.S.A.* (2001) 5671–5676.
- [32] E.R. Simpson, Y. Zhao, V.R. Agarwal, M.D. Michael, S.E. Bulun, M.M. Hinshelwood, S. Graham-Lorence, T. Tun, C.R. Fisher, K. Qin, C.R. Mendelson, Aromatase expression in health and disease, *Recent Prog. Horm. Res.* 52 (1997) 185–214.
- [33] V.R. Agarwal, S.E. Bulun, E.R. Simpson, Use of alternative promoters to express the aromatase cytochrome P450 (*CYP19*) gene in neoplastic and non-neoplastic adipose tissues of breast cancer patients, *J. Clin. Endocrinol. Metab.* 81 (1996) 3843–3849.
- [34] Y. Zhao, V.R. Agarwal, C.R. Mendelson, E.R. Simpson, Estrogen biosynthesis proximal to a breast tumor is stimulated by PGE2 via cAMP, leading to activation of promoter II of the *CYP19* (aromatase) gene, *Endocrinology* 137 (1996) 5739–5742.
- [35] N. Harada, T. Utsune, Y. Takagi, Tissue-specific expression of the human aromatase cytochrome P450 gene by alternative use of multiple exons I and promoters, and switching of tissue-specific exons I in carcinogenesis, *Proc. Natl. Acad. Sci. U.S.A.* 90 (1993) 11312–11316.
- [36] E.R. Simpson, M. Dowsett, Aromatase and its inhibitors—significance for breast cancer therapy, *Recent Prog. Horm. Res.* 57 (2002) 317–338.
- [37] J. Bonnetterre, B. Thurlimann, J.F. Robertson, M. Krzakowski, L. Mauriac, P. Koralewski, I. Vergote, A. Webster, M. Steinberg, M. von Euler, Anastrozole versus tamoxifen as first-line therapy for advanced breast cancer in 668 postmenopausal women: results of the Tamoxifen or Arimidex Randomized Group Efficacy and Tolerability Study, *J. Clin. Oncol.* 18 (2000) 3748–3757.
- [38] H. Mouridsen, M. Gershanovich, Y. Sun, R. Perez-Carrion, C. Boni, A. Monnier, J. Apffelstaedt, R. Smith, H.P. Sleeboom, F. Janicke, A. Pluzanska, M. Dank, D. Becquart, P.P. Bapsy, E. Salminen, R. Snyder, M. Lassus, J.A. Verbeek, B. Staffler, H.A. Chaudri-Ross, M. Dugan, Superior efficacy of letrozole versus tamoxifen as first-line therapy for postmenopausal women: results of a phase III study of the International Letrozole Breast Cancer Group, *J. Clin. Oncol.* 18 (2000) 3758–3767.
- [39] J.M. Nabholz, A. Buzdar, M. Pollak, W. Harwin, G. Burton, A. Mangalik, M. Steinberg, A. Webster, M. von Euler, Anastrozole is superior to tamoxifen as first-line therapy for advanced breast cancer in postmenopausal women: results of a North American multicenter randomised trial. Arimidex Study Group, *J. Clin. Oncol.* 18 (2000) 3758–3767.
- [40] M. Watanabe, E.R. Simpson, C.D. Clyne, P450 aromatase expression in human osteoblast-like (SV-HFO) cells, *Mol. Endocrinol.*, in press.